

# **Lightning and Grounding Evaluation of the BlueSky Standard Mast**

---

**OFFICIAL REPORT:**

**Laboratory and Field Testing Results**

**May 2, 2008**

**Document - 080501A Revision 1**

BlueSky Mast Inc - Copyright 2008 - All Rights Reserved.

206 E Waters Avenue, Tampa FL. 33604 – Phone 877-411-6278

[www.BlueSkyMast.com](http://www.BlueSkyMast.com)

## **Executive Summary**

We found the BlueSky Standard Mast capable of adequately conducting lightning strikes by comparison of the physical parameters of the mast to widely used industry lightning protection standards. Where some of the mast characteristics deviated from these standards (as is common in mobile mast systems) testing was conducted to verify adequate performance of the system.

The BlueSky radial mast grounding system (Part Number: BST2-K-L104-BSM-000) was evaluated and found to be superior in establishing a low impedance earth ground. Testing, using traditional low-frequency and novel high-frequency techniques validates this conclusion.

The following report details the tests and findings.

## 1.0 Introduction

The BlueSky Standard Mast with radial grounding system was evaluated for grounding and lightning strike performance.

### 1.1 Product Description

The BlueSky Standard Series Mast is a compact, one-person deployable, tripod-based, sectional mast capable of heights from 2 to 15 meters available in 1 meter increments. Each 1-meter mast section is individually machined from an aluminum alloy. The interlocking sections allow 360 degree rotation of the erected mast from the base. The tripod features an orienting compass, built-in bubble levels for adjusting each extendable leg's height for vertical integrity on sloped surfaces, Velcro cable management and threaded receptacles for mounting optional accessories, such as winching, grounding, solar panels and lanyard cleats.

### 1.2 Scope of Investigation

Components evaluated include: Aluminum Alloy Tripod with Level & Base Plates, AL1 Base Pole, AL1 Center Mast Poles, Mounting Pole, and Radial Grounding Kit. The Radial Grounding Kit is comprised of 3 stainless steel cable with 5 stakes on each radial. (See figure 3.) These components were subjected to compliance to standards and subjected to electrical testing, as described below.

### 1.3 Methodology

Testing and inspection was performed to assess compliance to the requirements of National Fire Protection Standard 780, Standard for the Installation of Lightning Protection Systems, (NFPA 780). Where necessary, additional testing was performed.

## 2.0 Lightning Interactions

Mast equipment is a likely point of lightning attachment. In these cases, lightning would most likely attach to equipment mounted atop the mast.

However, it is possible although less likely that lightning could attach directly to the mast assembly itself. Either way, the mast barrel becomes a conductor for lightning current. Thence the lightning current seeks a path to ground. In the configuration evaluated, the mast is equipped with a radial grounding system. The lightning current would then seek a path through the lowest grounding impedance, provided by design with this grounding system.

Therefore, the evaluation has to include the ability of the aluminum mast barrel to receive and more importantly, conduct, a lightning strike. This includes the junctions in the mast barrel and connections to it, namely, the connection to the grounding system. From this connection to the grounding system, the components of the grounding system must carry the lightning current without damage and dissipate it effectively to the earth.



Figure 1. BlueSky Standard Mast Base with Grounding Bracket

## 2.1 Direct Lightning Interception

Ability to directly intercept lightning without damage is assessed by comparison to the NFPA 780 Table 4.1.1.1(A), Minimum Class I Materials Requirements. Class I materials are used for components of lightning protection systems that are under 75 feet above grade. For an aluminum air terminal, minimum wall thickness is 0.064 inch, while the measured wall thickness of the BlueSky mast barrel is 0.094 inches. We can conclude that the BlueSky mast exceeds the air terminal requirement and is therefore suitable to accept direct lightning strikes without damage.

Required Thickness [in.]	Measured Thickness [in.]	Conclusion	Notes
0.064	0.094	Pass (Exceeds)	NFPA Table 4.1.1.1(A)

Table 1. Material Thickness for Direct Strike Reception

## 2.2 Mast Barrel Lightning Conduction

Ability to conduct lightning without damage is also assessed by comparison to the NFPA 780 Table 4.1.1.1(A), Minimum Class I Materials Requirements. Class I materials are used for components of lightning protection systems that are under 75 feet above grade. For an aluminum main lightning conductor, solid strip, minimum thickness is 0.064 inch and the total cross sectional area is 98,600 circular mils, or 0.077 sq. in. The equivalent BlueSky mast barrel cross-section is 1.068 sq. in. and 0.094 inch thick. We can conclude that the BlueSky mast exceeds the material requirement for thickness and cross-section and is therefore suitable to conduct lightning current without damage.

Required Cross-section [sq. in.]	Measured Cross-section [sq. in.]	Conclusion	Notes
0.077	1.068	Pass (Exceeds)	NFPA Table 4.1.1.1(A)

Table 2. Mast Barrel Cross-section for Use as Main Conductor

## 2.3 Mast Barrel Inter-Section Electrical Connection

The next assessment is the quality of electrical connection between sections. This assessment is not comparable to standards in the NFPA 780 and is unique to mobile systems. It is impractical to provide a compression or similar electrical fitting at the joint between mast barrel sections.

Ability to conduct lightning without damage is also assessed by comparison to the NFPA 780 bonding requirements for metal strike terminations (devices intended to receive a lightning strike) to the main conductor, found in paragraph 4.8.8. Three square inches is required, each contact area of the BlueSky mast is over 25 square inches. We can conclude that the BlueSky mast exceeds the material requirement for cross-section and is therefore suitable to conduct lightning current without damage.

Required Cross-section [sq. in.]	Measured Cross-section [sq. in.]	Conclusion	Notes
3.0	25.1	Pass (Exceeds)	NFPA 780: 4.8.8

Table 3. Mast Inter-Barrel Electrical Connection for Direct Strike Conduction

In addition to the material comparison, an electrical test was also performed as each mast barrel junction is not a compression fitting, rather, it is held together by the weight of the mast and mast head load and the downward force of the guy wires acting on the mast. Inspection of the mast junction reveals anodization on the interior and an oxidization of the exterior joint surface. Under common resistance measurements, the resistance is high due to these coatings. However, the joint is similar to any other aluminum mast



Figure 2. BlueSky mast inter-section barrel interface.

system. Testing revealed that once the anodization and oxide surfaces were scratched (as they do become through repeated use) the resistance value was quite low. It was also found that a higher voltage (1000 volts) easily punches through these coatings. (This measurement was performed with an AEMC 1045 Megaohmmeter.) As a lightning event is far in excess of this voltage, we expect it will easily punch through the coating (in fact, to a much greater extent than the AEMC 1045 Megaohmmeter is capable of) and the mast barrel junctions will provide a good electrical connection for lightning. A measurement with deliberate coating removal yielded very low resistances as tabulated in Table 4.

Signal Voltage [V]	Resistance [ $\Omega$ ]	Qualitative Assessment	Notes
12	Off-scale ( $>1G\Omega$ )	High resistance	
250	Off-scale ( $>1G\Omega$ )	High resistance	
500	Off-scale ( $>1G\Omega$ )	High resistance	
1000	2.7*	Adequate connection	Coating burnthrough occurs after short exposure to higher voltage.

Notes: \* Deliberate removal of anodization and oxidation yielded a resistance of  $202.5 \mu\Omega$ , measured with an AEMC DLRO 10 microohmmeter. Measurement was taken under a 10 A driving current.

Table 4. Mast Inter-barrel resistance in response to high voltage.

We conclude that the mast would effectively carry lightning current despite the coatings. While this is not strictly in compliance with NFPA 780 standards, it is typical and comparable to other sectional mobile mast systems.

## 2.4 Mast Barrel Electrical Connection to Ground

The mast barrel utilizes a grounding bracket to connect to the grounding electrodes. It is a compression fitting, with over 8 sq. in. of contact area, exceeding the NFPA 780 requirement (in paragraph 4.16.3). This bracket is positioned more than 18 inches above the baseplate (which contacts grade) with a bimetallic connector provided (for use with other grounding conductors, if needed) in fulfillment of the requirements of NFPA 780 Paragraph 4.5. Although the connection has a cross section contact in excess of the requirement from NFPA 780, it was noted that the anodization was not removed. A resistance test was performed to determine the suitability of the connection. Using the AEMC DLRO 10 microohmmeter, this connection was found to have a resistance of 13.39 mΩ, based on a 10-trial average. Test points were on the anodized bracket surface and on the inner mast barrel interface. Oxidation on the mast barrel was sanded off for the test. Without sanding the mast barrel interface, the connection behaves similarly to the inter-section interface. A visible arc occurs briefly when a high voltage test signal (using the AEMC 1045 Megaohmmeter) is applied and the resistance drops sharply thereafter. (As accounted for in section 2.3 of this report.)

Required Cross-section [sq. in.]	Measured Cross-section [sq. in.]	Conclusion	Notes
8.0	8.7	Pass (Exceeds)	NFPA 780 :4.16.3
Resistance: 13.39 mΩ, using AEMC DLRO 10 Microohmmeter, 10-trial average.			

Table 5. Mast to Grounding Bracket Cross-section.

Given the low resistance and large cross-section of this contact, we assess it as suitable for lightning protection purposes.

## 3.0 Grounding System

The mast grounding subsystem was also evaluated. Although a specific value is not expressed by NFPA 780 for ground resistance in lightning protection systems, lower resistance and lower impedance is better to ensure controlled current flow. The goal is to keep the resistance and impedance to earth as low as possible. The BlueSky mast evaluated provides a surface earth electrode system, similar to the MK-2551 and MK-2900 grounding kits used by the U.S. Army. The BlueSky system more closely resembles the MK-2900, which provides three radial electrodes with five grounding stakes each. The center attachment point of the system is on the mast grounding bracket.

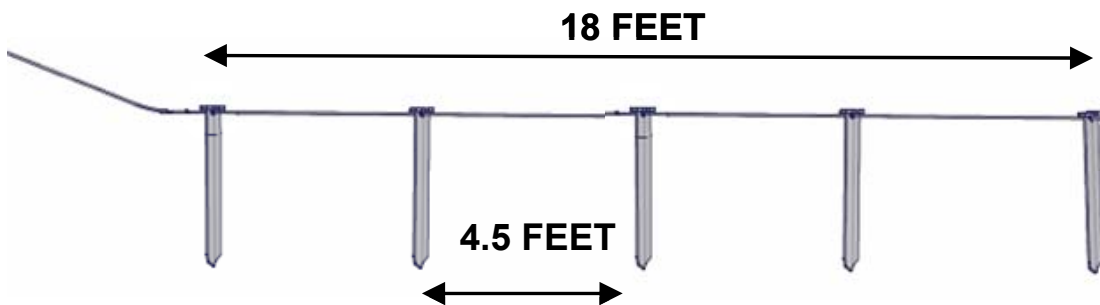

Figure 3. Single radial of mast grounding subsystem (not to scale.)

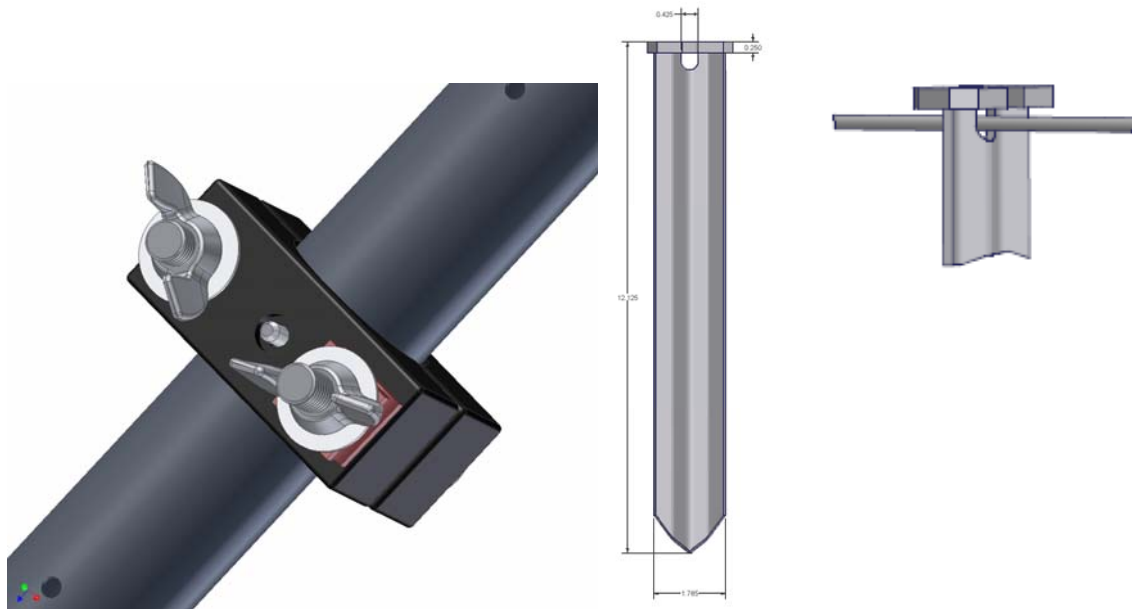

Figure 4. BlueSky mast grounding system bracket with bimetallic connector and grounding lug attachments (right) and stake detail showing cable penetration. Stakes are 12.125 inch long and 1.765 inches wide. Cable is ¼-inch diameter steel.

Optimal setup of the grounding system is to emplace the stakes as far apart as practical, given the position of the mast and the length of wire available. In the test of the BlueSky system, in each radial 18 feet of cable was used to emplace the stakes (5 stakes, each spaced 4.5 feet apart) and the remainder used to connect to the grounding bracket. Each stake was twisted and emplaced flush with grade to ensure the best possible cable-to-stake contact. For comparison purposes, a standard 6-foot ground rod was also measured. Soil resistivity measurements were also taken at shallow (2 ft.) and deeper (6 ft.) profiles (see Table 7.) The standard Wenner 3-point fall of potential test was used. Measurements were taken at power line frequencies (60 Hz) and frequencies up to 1 MHz, which give a better profile of the behavior of the lightning performance of the grounding system. Instruments used for this testing were the Extech Ground Resistance Meter, the NGI Unilap Geo X Ground Tester and the SEFTIM AES 1002 High Frequency Ground Tester.

### 3.1 Grounding System Connection to Grounding Bracket

This electrical connection was measured with the AEMC DLRO 10 microohmmeter. This instrument uses a four-point method which cancels contact resistance. In addition, it has the capability to drive the connection at currents up to 10 A. This ability makes it possible to detect connections of small cross-section that would not be suitable for lightning conduction.

Connection of each grounding radial to the mast grounding bracket is done by a wingnut and lug compression assembly, common on military and mobile equipment.

Resistance [mΩ]	Conclusion	Notes
75.5	Adequate connection	Result is average of 10 trials with AEMC DLRO 10. Anodization was not removed on bracket outer surface.

Table 6. Grounding radial electrical connection.

### 3.2 Low Frequency Grounding Resistance Measurements

Grounding System	Resistance [ $\Omega$ ]	Normalized Resistance	Notes
BlueSky Radial	134	0.20 $\rho$	$\rho=661.9 \Omega\text{-m}$ , @ 2 ft. depth
6-foot Rod	384	0.40 $\rho$	$\rho=948.6 \Omega\text{-m}$ , @ 6 ft. depth

Table 7. Low frequency grounding resistance measurements

From the low frequency results, we conclude that the BlueSky radial system provides a lower resistance ground than the 6-foot ground rod. This result is comparable to the Army MK-2551 grounding system (a ring conductor system) which has a normalized resistance of approximately 0.14 $\rho$ .

### 3.3 Lightning Survivability of the Grounding System

Assessment of the ability of the grounding components to survive a lightning strike is done by comparison of tests performed on similar systems and components. Specifically, a survivability of the ¼-inch steel interconnecting cable for the ground stake components might be questioned. Testing performed in the past revealed that these components, including the steel cable, survive very high magnitude lightning currents. (Ref. 2 & 3.) From comparison, we conclude that components of the grounding system have sufficient cross section and mechanical strength to survive a lightning strike.

### 3.4 High Frequency Grounding Measurements

Advanced grounding measurements of the BlueSky Mast Grounding System were conducted to determine its performance under lightning conditions. In recent years, it has become apparent that traditional resistance measurements of grounding systems using direct current or at low frequencies emulating power circuits do not give an accurate portrayal of the impedance under lightning surge current conditions. In extreme cases, the impedance of a standard ground rod is observed to be so high as to actually cause rejection of the lightning current, which then travels along the surface of the earth, a lower impedance path. Results of this test at frequencies from 0.5 MHz to 1.0 MHz will be the most indicative of the behavior under lightning conditions.

In this test, the BlueSky Mast grounding system was subjected to a standard Wenner 3-point fall of potential test at a number of frequencies from 79 Hz to 1 MHz using the SEFTIM AES 1002 High-Frequency Earth Tester. A six-foot ground rod was also subjected to this test for comparison purposes.

The data shows that the BlueSky Mast Grounding System maintains an advantage in having a lower impedance across the range of test frequencies. (These results may also be useful for signals grounding, as well as lightning performance.) To judge lightning performance we must examine the range from 0.5 MHz to 1.0 MHz. We notice that the BlueSky system impedance is actually decreasing from 0.5 MHz to 0.8 MHz and stays constant through 1 MHz.

If the impedance is normalized to soil resistivity at the appropriate depth profile (figure 6), we find that the impedance of the ground rod converges with the Blue Sky Mast system from 0.08 to 0.50 MHz, then a sharp divergence continues up to 1 MHz. Explanations for these phenomena can be obtained by viewing the detailed test results at Annex A. It is observed that

the reactance for the BlueSky system is trending toward zero more rapidly with an increase in frequency while it is fairly flat for the standard ground rod in this same range. Also, resistance for the BlueSky system is lower and flat in this frequency region, while for the standard ground rod it is actually trending upward. We surmise this is a result of the lesser surface area of the ground rod compared to the BlueSky system (approximately 22 sq. in., compared to 642 sq. in., not considering the interconnecting cables.) As frequency increases, skin depth becomes less, similar to a lightning event. With a smaller skin depth, the amount of material participating in conduction is less and resistance increases. This effect will certainly be more pronounced in an actual lightning event, as the current density will be much higher in the grounding rod that has far less surface area than the BlueSky system.

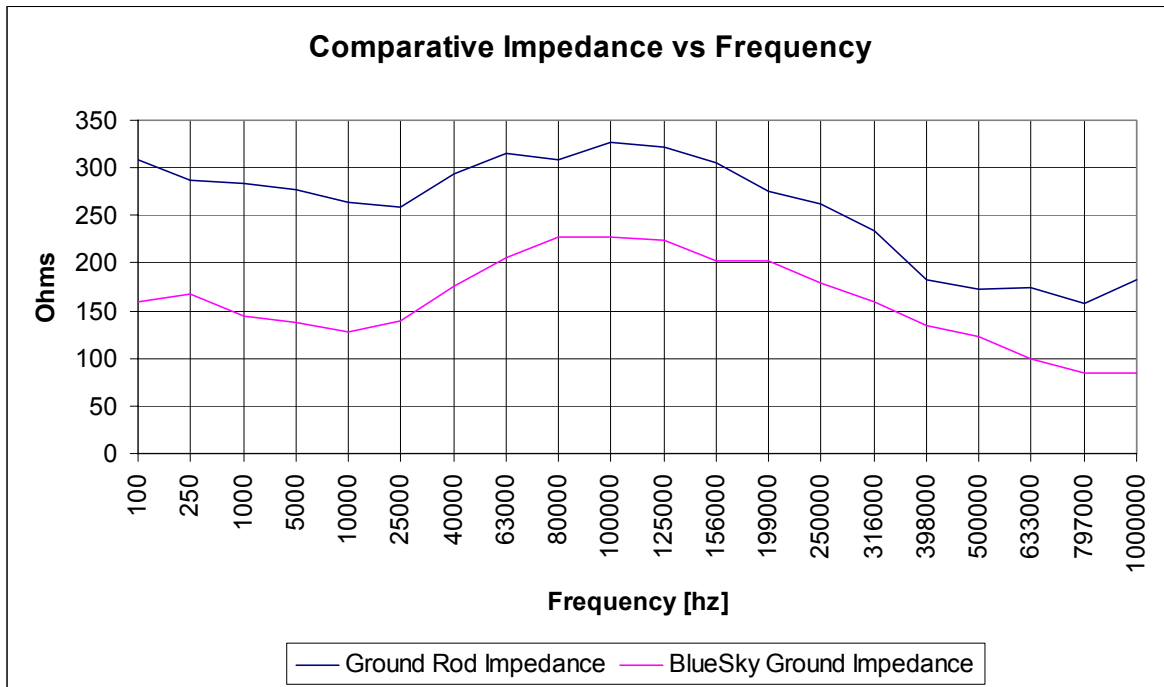

Figure 5. Comparison of BlueSky radial ground system impedance and standard ground rod.

#### 4.0 Performance Assessment

We expect that the BlueSky mast system will survive a lightning strike and function as an integral lightning protection system with the grounding system. Although the intersection joints are non-compliant with the requirements of NFPA 780 (which implies a continuous conductor) the testing reveals it will certainly respond to lightning current adequately. The grounding system is not strictly compliant with NFPA 780 either but is analogous to the radial grounding techniques (NFPA 780: 4.13.5 and 4.13.8.1.3&4.) Despite this, the test results show performance superior to a typically required ground rod. The testing used traditional figures of merit (low frequency resistance measurements) and test conditions emulating lightning performance. We also note that surface wire grounding techniques are in use by the US Army for upward of fifteen years for lightning, power and signal grounding applications.

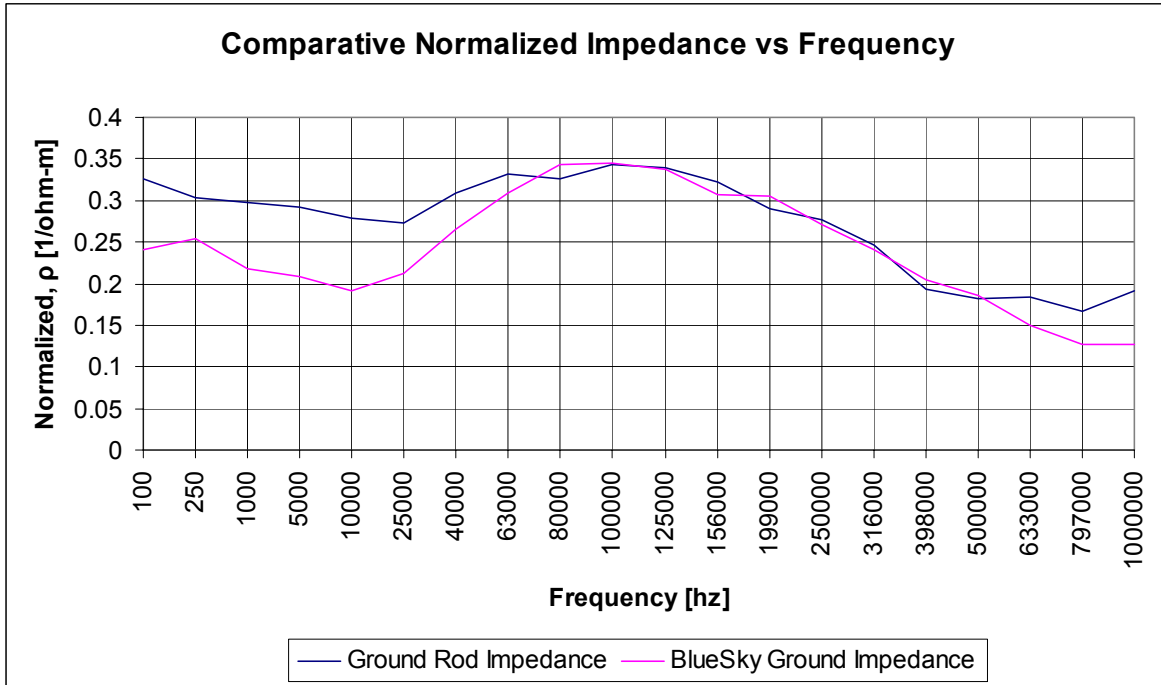

Figure 6. Comparison of BlueSky radial ground system impedance and standard ground rod.

## 5.0 Additional Lightning Safety Considerations

### 5.1 Step Potential

We need to briefly mention the concept of step potential for the purposes of safety. Step potential is a consequence of current injection into the earth. It is always manifest with grounding systems subjected to lightning current. When lightning current is injected into the earth, it moves outward from the grounding system flowing through earth. Since the soil is resistive, a voltage develops on the surface of the earth from this current flow. A voltage gradient develops as a function of distance from the grounding system. Since a voltage difference can exist between two points on the surface, an electric shock hazard is present. The implication is that the area near any grounding system subjected to lightning current is hazardous due to an electric shock hazard. In the BlueSky system, the magnitude of the step potential is distributed over a greater area and should create a more even distribution, resembling a voltage equipotential surface reducing the shock risk. However, since the exact performance cannot be predicted due to differences in possible lightning strikes, prudent avoidance of the vicinity of the grounding system should be exercised in the event of lightning activity.

### 5.2 Flashover

Similarly, we need to briefly discuss flashover in lightning protection systems. When lightning current flows through any conductive components, the impedance of the component results in a voltage relative to ground. If this voltage becomes high enough and a grounded object is in

close proximity, the lightning current can travel through the air to the adjacent grounded object. This phenomena is called 'flashover' or sometimes 'sideflash.' While the BlueSky mast system is tested to be a good conductor of lightning current, there will always be some impedance and consequently a voltage difference between the mast and earth ground, if subjected to a lightning strike. Consequently, the area near the mast (or any mast, tree or similar object) needs to be avoided during lightning strike conditions.

## 6.0 References

[1] National Fire Protection Association Standard 780 (2008 edition), "Standard for the Installation of Lightning Protection Systems," National Fire Protection Association, Quincy, MA, 2008.

[2] "Testing of Ground Conductors with Artificially Generated Lightning Current," IEEE Transactions on Industry Applications, Vol. 32, No. 3, May/June 1996.

[3] USACECOM Technical Report 94-8, MK-2551 Grounding Kit (Surface Wire Ground System): Engineering Application Notes, February 1994.

[4] USACECOM Technical Report 93-1, *Lightning Protection System Applications for Tactical Communications Systems*, January 1993.

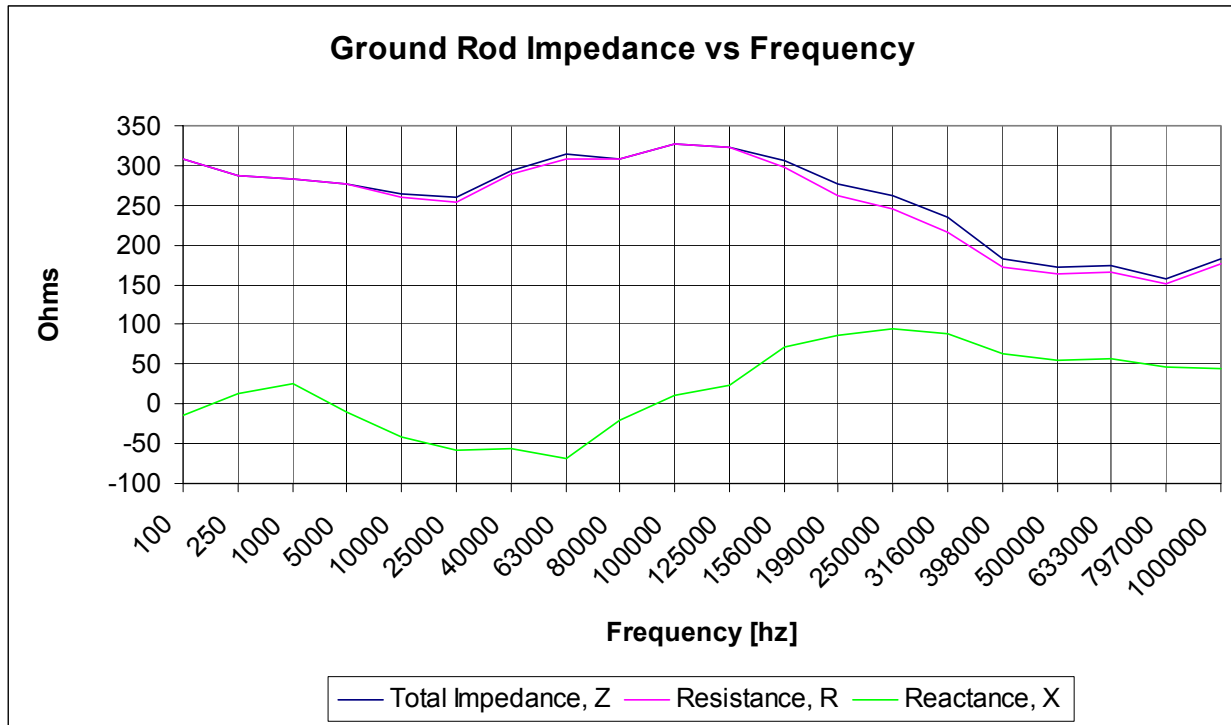

Figure A1 Standard ground rod results.

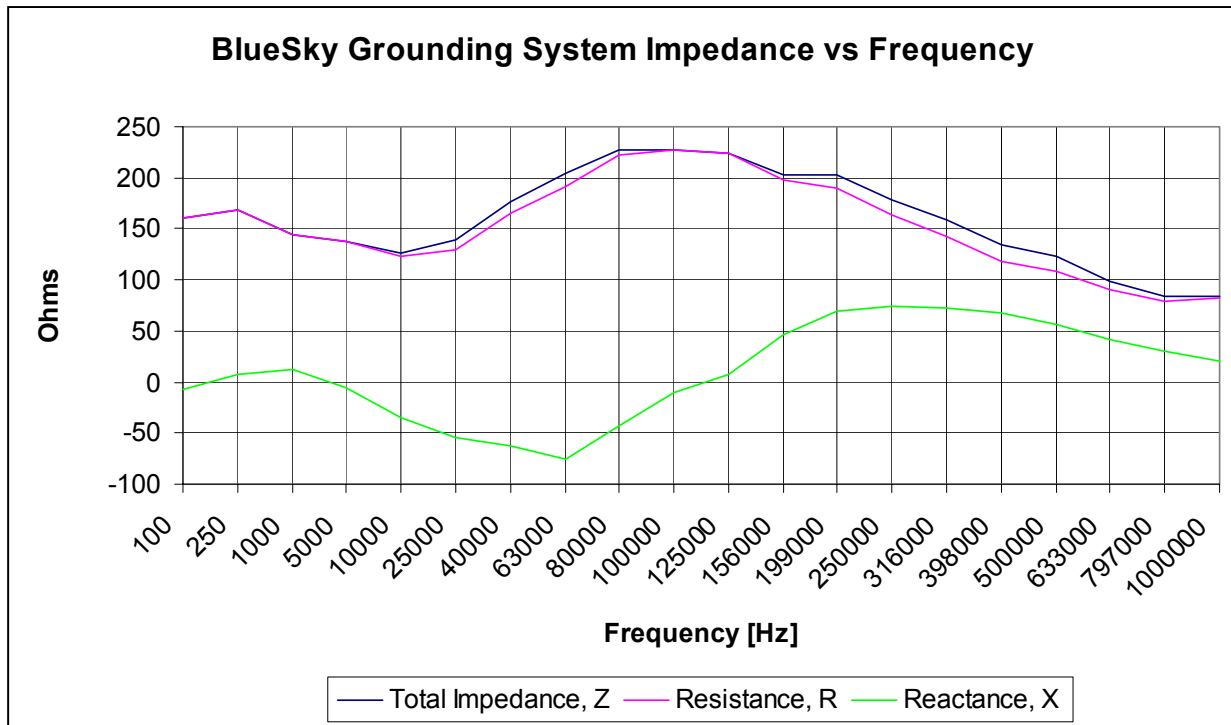

Figure A2 BlueSky radial grounding system results.

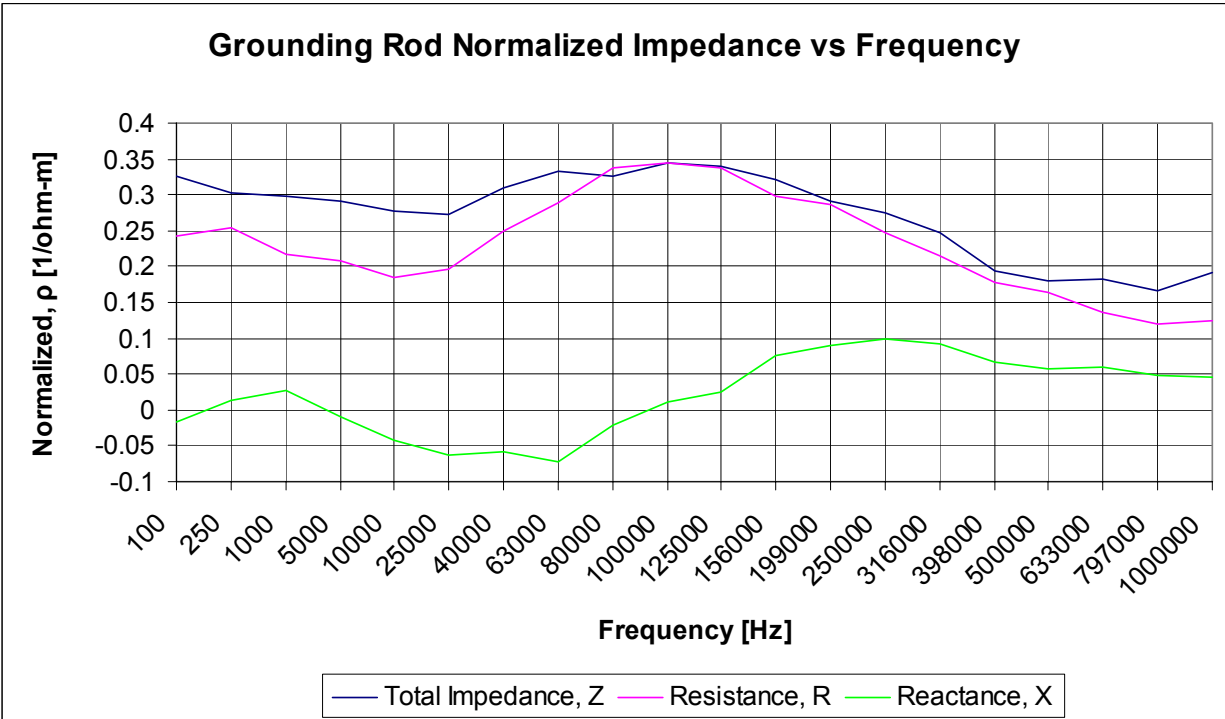

Figure A3. Standard ground rod normalized results.

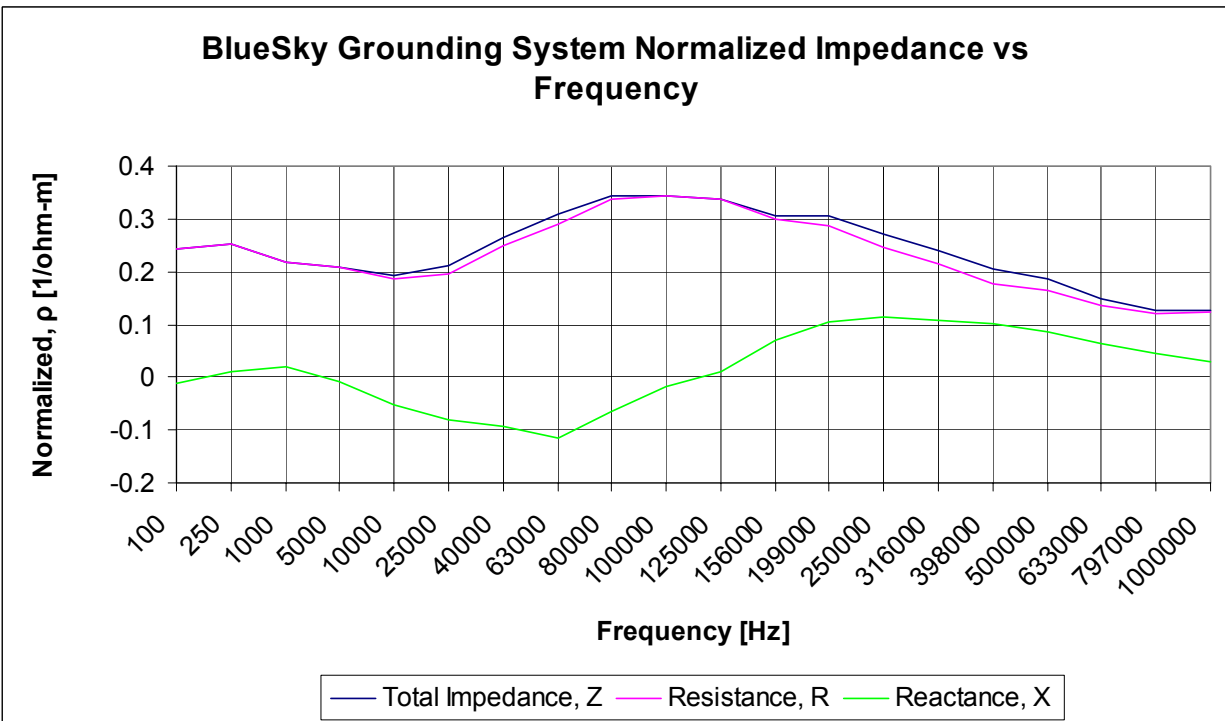

Figure A4. BlueSky radial ground normalized results.